

**Besdia®**  
一品鑽石工業股份有限公司  
Best Diamond Industrial Co., Ltd.

總公司：24872 新北市五股區中興路一段10號4樓（大都市科學園區B棟）  
Office：4F., No.10, Sec. 1, Chung Hsing Rd., Wugu Dist, New Taipei City 248, Taiwan  
電話 / TEL：02-8976-9341（代表號） 傳真 / FAX：02-8976-9343 / 8976-9484

台中服務處：40874 台中市南屯區三和里三厝街230號  
電話 / TEL：04-2259-8922 傳真 / FAX：04-2254-4785

網址：<http://www.besdia.com> 信箱 / E-mail：[service@besdia.com](mailto:service@besdia.com)

**Besdia®**

**GRINDING · DEBURRING · POLISHING**  
**/ PRODUCT CATALOG /**



[www.besdia.com](http://www.besdia.com)  
一品鑽石工業股份有限公司  
2016-10 NO.2

[www.besdia.com](http://www.besdia.com)  
破繭而出 超越自我 再創高峰

# Evolved Emerged Transcended

破繭而出 超越自我 再創高峰

# Besdia®

## CE證書 / CE CERTIFICATION



## 索引 / Index

P.1~8.....超音波振動研磨機 / Ultrasonic Lapping Machine

P.9~13.....電動工具-電源控制器 / Rotary Micromotor Controller

P.14.....電動旋轉手機 / Rotary Handpiece

P.15~16.....氣動旋轉刻磨機 / Air Grinders

P.17~18.....氣動銼磨機 / Pneumatic Reciprocating Lappers

P.19~27.....專業研磨與拋光工具 / Professional Grinding & Polishing Tools

## ISO9001認證 / ISO9001 CERTIFICATION

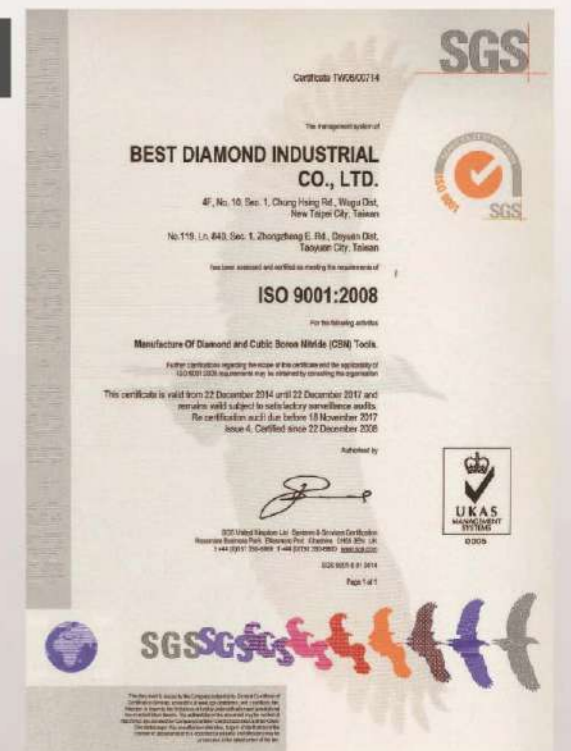

# 超音波振動研磨機 / Ultrasonic Lapping Machine

AR-800 目錄頁數 P.3 / Page. 3



AR-108 目錄頁數 P.4 / Page. 4



AR-600 (E) 目錄頁數 P.5 / Page. 5



AR-600 目錄頁數 P.6 / Page. 6



Ultrasonic Lapping Machine with micro vibration stroke and extra-high frequency (22,000 times per second), which can easily handle most intricate jobs for various molds and dies.

The difficult traditional process of slots, ribs, detail corners, intricate areas becomes so easy with time saving, and efficiently reach a quality result of polishing and finishing Process.

## Features:

- \* **Powerful output :**  
Max.45 watts of output power enables you to achieve any polishing task at the best performance.
- \* **Auto feedback system :**  
Machine itself will automatically adjust frequency according to different tools to get the best performance.
- \* **Electronic transformer with regulation :**  
To maintain the machine in good performance and protect it from damage even at an unstable supply of electric voltage.
- \* **Detecting circuit of suspending :**  
When handpiece is not in used, the unit will automatically reduce the output power. It does not only prolong the life of the handpiece transducer but also keep the tools from heating up .

## Applications:

- \* For polish and grinding of the mold & die.
- \* For cutting and deburning of plastics on intricate area.
- \* For correction of PCB patterns.
- \* For fine engraving or polishing of stone, glass and jewelry.
- \* For cutting of rubber film, clothe, etc.



超音波振動研磨機，以每秒兩萬多次的超高頻微細振動，可輕鬆地解決各種模具的複雜或細微部位之加工。

以前難以加工的溝槽、肋骨、角落或複雜及微細等部位，現在使用超音波振動研磨機，將可有效地且省時地完成各種模具之研磨及拋光工作。

## 運用:

- \* 各種磨具之研磨及拋光。
- \* 塑膠製品複雜、精細部位之切斷或去毛邊。
- \* 印刷電路板(PCB)電子迴路修改。
- \* 石頭、玻璃、寶石等之精細雕刻或拋光。
- \* 布、橡膠薄膜等之切斷。

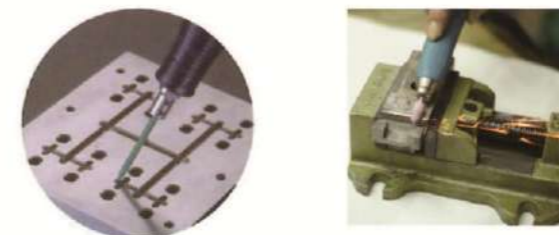

## 特長:

- \* **強勁的輸出功率:**  
最大45瓦的輸出功率，提供有效且快速之加工作業。
- \* **自動追尾迴路:**  
機器會根據各種不同工具，自動檢測並選擇最佳之輸出振頻以發揮各種工具之最佳性能。
- \* **電子穩壓變壓器:**  
電子變壓器兼具穩壓效果，即使在電源不穩定之情況下，依然可維持機器良好的操作性能，且可保護機器不致受損。
- \* **空振檢知迴路設計:**  
當手機未與工件接觸時，機器會自動降低輸出功率，以延長手機壽命，並可防止工具因空振導致發燙或燒毀。

## 專業研磨與拋光工具 / Professional Grinding & Polishing Tools



鑽石磨棒  
Diamond Mounted Points



鑽石機械銼刀  
Diamond Machine Files



陶瓷纖維油石  
Ceramic Fiber Stones

目錄頁數 P.22 / Page. 22



鑽石膏  
Diamond Compounds



羊毛輪  
Felt Bobs

目錄頁數 P.21 / Page. 21



彈性帶柄砂輪  
Elastic Mounted Points

目錄頁數 P.27 / Page. 27

- ※ 一品鑽石提供以上專業的拋光與研磨工具，適用於所有的電動拋磨機使用，歡迎選購
- ※ 以上連結之QR CODE 可直接連線到一品鑽石的線上目錄，若無法使用 QR CODE 請至 [www.besdia.com](http://www.besdia.com) 查閱詳細產品規格
- ※ We supply professional polishing and grinding tools , your interest & business will be warmly welcomed.
- ※ Please use QR Code to connect with BEST DIAMOND' s catalogue online. Or please visit our website at [www.besdia.com](http://www.besdia.com)

AR-800旗艦多功能型  
Multi-function Flagship Type

Flagship 旗艦主打



AR-800 超音波振動研磨機 - 標準規格表  
Ultrasonic Lapping Machine - Specification

電源控制器 Power Controller	
電源 Main supply	AC-90V ~ 250V, 50/60 Hz
超音波輸出 Ultrasonic output	45 watts
振頻 Vibration frequency	18 ~ 26 kHz
振幅 Stroke amplitude	3 ~ 40 μm
振頻調整 Frequency adjustment	自動追尋 / auto-tracing
消耗功率 Power consumption	300 watts
保險絲 Fuse	3A time-lag type
直流馬達輸出 Output of DC motor	5 ~ 32V
有刷輸出功率 Power of DC brush	Max. 150 watts
無刷輸出功率 Power of DC brushless	Max. 300 watts
尺寸 Dimensions	170x260x140mm
重量 Weight	2.72 kg
手機 Handpiece	
超音波手機 Ultrasonic handpiece	* GS-H26
尺寸 Dimensions	Ø27x125mm
重量 Weight	150g
旋轉手機 Rotary handpiece	
有刷手機 Brush handpiece	⊙
無刷手機 Brushless handpiece	U-Lap 60

註/ Note : \* 亦可選用GS-H04手機 / GS-H04 could be selected instead of the model  
⊙ 選購配備 / Optional accessory

基礎應用實例 (Applications):



全新設計旗艦型機種，擁有最先進的多功能設計，結合超音波，有刷及無刷直流等三種輸出。

- 無刷直流輸出最大300瓦，有刷直流輸出最大150瓦，提供各種手機有更高的扭力，發揮其最佳的研磨效果。
- 先進的高效率微處理器，使超音波的拋光效果更加穩定，更有效率。
- 在使用無刷手機時，LED轉速顯示，讓您可依據各種不同的工具，調整最合適轉速，以達到最有效率且安全的研磨效果。
- 每次啟動機器，系統會自動地將轉速歸“零”，避免因手機高速啟動而造成危險。
- 本機之標準配備含有超音波手機(GS-H26)及無刷旋轉手機(U-Lap 60)各一支。

With the most advanced design that provides the multi-function of Ultrasonic, Brush DC (direct-current) and Brushless DC output.

- All new design with high-efficiency microprocessor that give the machine with perfect performance.
- The brushless DC with max. 300 watts and brush DC with max. 150 watts output power that gives your handpiece with high torque and high speed running.
- The LED speed display shows you the running speed of brushless handpiece. You can select the best and safe speed according to various tools and diameter.
- Once turn on the machine, the system will automatically adjust the speed to “Zero”, that keep you away from the damage caused by high speed running of handpiece.
- This machine includes one each of ultrasonic and brushless handpiece.

AR-800 整組實際內容物 (標準組)  
AR-800 set include (Standard)

超音波手機 Ultrasonic Handpiece		(GS-H26) Ø27x125mm
無刷手機 Brushless handpiece		(U-Lap60) Ø29x161mm
電源線 Power Cord		18AWG x3Cx180cm
手機線 Handpiece Cord		3Cx150cm
六角扳手 Wrench (HEX)		HEX (62mm)
手機座 Handpiece Rest		110x50x35 mm
夾頭拆卸架 Tool Changing rack		For 10mm Holder
扳手 Wrench		140mm (10/12)
轉接頭 (M6) Adapter (M6)		For M6 Shank Tool
夾頭 (Ø3.0mm) Holder (Ø3.0mm)		For Ø3mm shank Tool
夾頭 (3.0mm) Holder (3.0mm)		For oil Stone (3mm)
夾頭 (1.0mm) Holder (1.0mm)		For ceramic Fiber Stone (1.0mm)
腳踏開關 Foot Switch		Cord Length 150cm

AR-108單功能型  
Single Function Practical Type

TOP SALE!!  
熱銷商品!!



AR-108 超音波振動研磨機 - 標準規格表  
Ultrasonic Lapping Machine - Specification

電源控制器 Power Controller	
電源 Main supply	AC-90V ~ 250V, 50/60 Hz
超音波輸出 Ultrasonic output	40 watts
振頻 Vibration frequency	18 ~ 25 kHz
振幅 Stroke amplitude	10 ~ 35 μm
振頻調整 Frequency adjustment	自動追尋 / auto-tracing
消耗功率 Power consumption	46 watts
保險絲 Fuse	2A time-lag type
直流馬達輸出 Output of DC motor	無 / None
有刷輸出功率 Power of DC brush	無 / None
無刷輸出功率 Power of DC brushless	無 / None
尺寸 Dimensions	192x156x96mm
重量 Weight	0.7 kg
手機 Handpiece	
超音波手機 Ultrasonic handpiece	GS-H06
尺寸 Dimensions	Ø30x130mm
重量 Weight	175g

AR-108 整組實際內容物 (標準組)  
AR-108 set include (Standard)

超音波手機 Ultrasonic Handpiece		(GS-H06) Ø30x130mm
電源線 Power Cord		18AWG x3Cx180cm
手機線 Handpiece Cord		3Cx150cm
六角扳手 Wrench (HEX)		HEX (62mm)
手機座 Handpiece Rest		110x50x35 mm
夾頭拆卸架 Tool Changing rack		For 11mm Holder
扳手 Wrench		140mm (10/11)
夾頭 (Ø3.0mm) Holder (Ø3.0mm)		For Ø3mm shank Tool
夾頭 (1.0mm) Holder (1.0mm)		For ceramic Fiber Stone (1.0mm)
腳踏開關 Foot Switch		Cord Length 150cm

基礎應用實例 (Applications):



## AR-600(E)雙功能強力型 Dual-function Powerful Type



AR-600E 超音波振動研磨機 - 標準規格表  
Ultrasonic Lapping Machine - Specification

電源控制器 Power Controller	
電源 Main supply	AC-90V ~ 250V, 50/60 Hz
超音波輸出 Ultrasonic output	45 watts
振頻 Vibration frequency	18 ~ 26 kHz
振幅 Stroke amplitude	3 ~ 40 μm
振頻調整 Frequency adjustment	自動追尋 / auto-tracing
消耗功率 Power consumption	80 watts
保險絲 Fuse	2A time-lag type
直流馬達輸出 Output of DC motor	5 ~ 30V
有刷輸出功率 Power of DC brush	Max. 60 watts
無刷輸出功率 Power of DC brushless	無 / None
尺寸 Dimensions	170x260x140mm
重量 Weight	2.0 kg
手機 Handpiece	
超音波手機 Ultrasonic handpiece	GS-H04
尺寸 Dimensions	Ø33x146mm
重量 Weight	254g
旋轉手機 Rotary handpiece	
有刷手機 Brush handpiece	◎

註/ Note : ◎ 選購配備 / Optional accessory

## 基礎應用實例 (Applications):

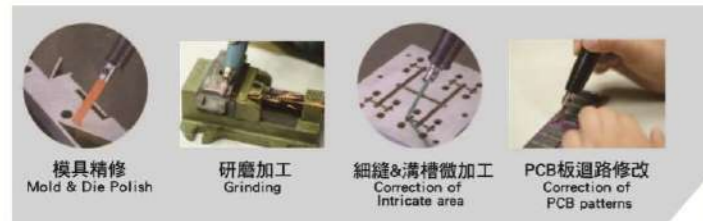

- AR-600(E)為AR-208, AR-303之升級版。全新的設計, 採用高效率微處理器使操作性能更穩定且提升拋光效率。
- 超音波及DC馬達雙輸出, 提供您雙重功能之各種研磨及拋光作業。
- 最大45瓦之超音波輸出, 使拋光效率更加提升。
- 有刷DC馬達輸出電壓為5-30伏特, 輸出功率為60瓦。
- AR-600(E) is the upgrade model of AR-208 and AR-303. All new design with high-efficiency microprocessor that gives the machine with more steady and effective performance.
- This dual-function machine provides you the versatility of both Ultrasonic and mechanical polishing.
- Max.40 watts output that satisfy various of polishing works.
- Max. 45 watts Ultrasonic output makes polishing job more effective.
- Brush DC motor output is 5-30 volt and output power is 60 watts.

AR-600E 整組實際內容物 (標準組)  
AR-600E set include (Standard)

超音波手機 Ultrasonic Handpiece		(GS-H04) Ø 33x146mm
電源線 Power Cord		18AWG x3Cx180cm
手機線 Handpiece Cord		3Cx150cm
六角板手 Wrench (HEX)		HEX (62mm)
手機座 Handpiece Rest		110x50x35 mm
夾頭拆卸架 Tool Changing rack		For 12mm Holder
扳手 Wrench		140mm (10/12)
夾頭 (Ø3.0mm) Holder (Ø 3.0mm)		For Ø 3mm shank Tool (2pcs)
夾頭 (3.0mm) Holder (3.0mm)		For oil Stone (3mm)
夾頭 (1.0mm) Holder (1.0mm)		For ceramic Fiber Stone (1.0mm)
腳踏開關 Foot Switch		Cord Length 150cm

## AR-600三功能實用型 Triple Function Practical Type



AR-600 超音波振動研磨機 - 標準規格表  
Ultrasonic Lapping Machine - Specification

電源控制器 Power Controller	
電源 Main supply	AC-90V ~ 250V, 50/60 Hz
超音波輸出 Ultrasonic output	45 watts
振頻 Vibration frequency	18 ~ 26 kHz
振幅 Stroke amplitude	3 ~ 40 μm
振頻調整 Frequency adjustment	自動追尋 / auto-tracing
消耗功率 Power consumption	100 watts
保險絲 Fuse	2A time-lag type
直流馬達輸出 Output of DC motor	5 ~ 30V
有刷輸出功率 Power of DC brush	Max. 60 watts
無刷輸出功率 Power of DC brushless	Max. 100 watts
尺寸 Dimensions of	170x260x140mm
重量 Weight	2.0 kg
手機 Handpiece	
超音波手機 Ultrasonic handpiece	GS-H04
尺寸 Dimensions	Ø33x146mm
重量 Weight	254g
旋轉手機 Rotary handpiece	
有刷手機 Brush handpiece	U-Lap 35
無刷手機 Brushless handpiece	◎

註/ Note : ◎ 選購配備 / Optional accessory

## 基礎應用實例 (Applications):



- AR-600採用高效率微處理器設計, 使操作性能更穩定且提升拋光效率。
- 結合超音波, 有刷直流及無刷直流三種輸出, 滿足更多功能手機使用。
- 無刷直流輸出功率最大100瓦, 有刷輸出為60瓦。
- 無刷手機的優點為: 高轉速、高扭力、壽命長、低噪音, 不必更換碳刷且無碳刷產生的粉塵。
- AR-600 with high-efficiency microprocessor design that gives the machine with more steady and effective performance.
- Combine the Ultrasonic, brush DC and brushless DC output in one package, you can adapt most of the handpiece for your polishing work.
- Brushless DC output power is 100 watts and brush DC output power is 60 watts.
- The advantage of Brushless handpiece are : high speed, high torque, longer tool life, and low noise, no need to change carbon brush and no dust cause by carbon brush worn out.

AR-600 整組實際內容物 (標準組)  
AR-600 set include (Standard)

超音波手機 Ultrasonic Handpiece		(GS-H04) Ø 33x146mm
有刷手機 Brush handpiece		(U-Lap 35) Ø 29x152mm
電源線 Power Cord		18AWG x3Cx180cm
手機線 Handpiece Cord		3Cx150cm
六角板手 Wrench (HEX)		HEX (62mm)
手機座 Handpiece Rest		110x50x35 mm
夾頭拆卸架 Tool Changing rack		For 12mm Holder
扳手 Wrench		140mm (10/12)
夾頭 (Ø3.0mm) Holder (Ø 3.0mm)		For Ø 3mm shank Tool (2pcs)
夾頭 (3.0mm) Holder (3.0mm)		For oil Stone (3mm)
夾頭 (1.0mm) Holder (1.0mm)		For ceramic Fiber Stone (1.0mm)
腳踏開關 Foot Switch		Cord Length 150cm

# 超音波振動研磨機 / Ultrasonic Lapping Machine

## AR-800可搭配手機一覽表 Attachment Handpiece for AR-800



※ 標準配備用紅色顯示, 其餘皆為選購商品  
 ※ Standard Accessory that marking in RED, other Handpiece are Optional Accessory

## AR-600可搭配手機一覽表 Attachment Handpiece for AR-600



※ 標準配備用紅色顯示, 其餘皆為選購商品  
 ※ Standard Accessory that marking in RED, other Handpiece are Optional Accessory

## AR-600 (E)可搭配手機一覽表 Attachment Handpiece for AR-600 (E)

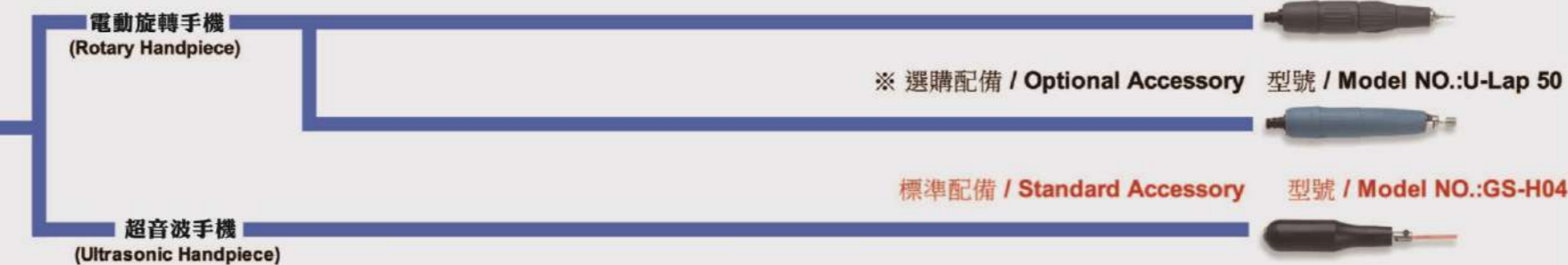

※ 標準配備用紅色顯示, 其餘皆為選購商品  
 ※ Standard Accessory that marking in RED, other Handpiece are Optional Accessory

## AR-108可搭配手機一覽表 Attachment Handpiece for AR-108



## 超音波手機 Ultrasonic Handpiece

型號 / Model No. : GS-H04



最大輸出 / Max. output : 45Watts  
 尺寸 / Size : Ø 33 x 146mm  
 重量 / Weight : 254g

型號 / Model No. : GS-H06



最大輸出 / Max. output : 40Watts  
 尺寸 / Size : Ø 30 x 130mm  
 重量 / Weight : 175g

型號 / Model No. : GS-H26



最大輸出 / Max. output : 40Watts  
 尺寸 / Size : Ø 27 x 125mm  
 重量 / Weight : 150g

※ 電動旋轉手機 (U-Lap 60, 50, 35)  
 請參閱目錄 P.14 有詳細介紹  
 ※ See the Rotary Handpiece on Page 14  
 You Can find all information!

AR-800(P) 目錄頁數 P.11 / Page. 11



Brand-new design, with its powerful output & precise controlling function, we provide various models for different grinding needs. Our (brand-new) design mainly focus on all kinds of safety function and avoid any risk of injury while operating the products.

With its friendly design and accurate rotational speed control, our products will make your job much easier and efficient. All of our models are made in TAIWAN so the quality and price advantage are both included. It would be much easier to handle polishing, grinding and engraving task, even the beginner can operate it without any difficulties. While using our products.

### Features:

#### \* Powerful output :

Max.250 watts of output power for our brushless models, Max.150 watts of output power for brush models enables you to achieve any polishing task at the best performance.

\* Wide ranges of input voltage are acceptable : Power AC60~250V, 50/60 Hz are all acceptable for our models. No need to worry about the inconsistent power supply.

\* Overload protection prevents : Build in overload protection prevents the hand piece from damage during an overloading.

AP-300 目錄頁數 P.12 / Page. 12

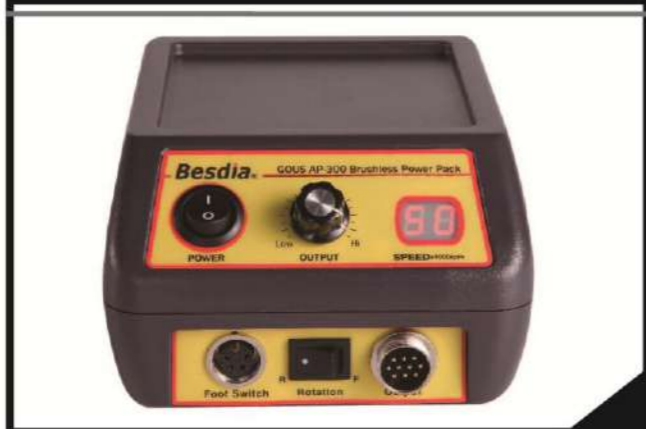

\* High-Efficiency microprocessor : Advanced High-Efficiency microprocessor will automatically detects the operation of hand-piece anytime, precisely controlling the output power, circuit protection, torque compensation and maintain the machine in good performance.

### Applications:

- \* For polishing & Grinding of the mold & die.
- \* Require precise speed control while processing (the work-piece).
- \* For carving hard & brittle materials or work-piece requiring high-speed procession.
- \* For fine engraving or polishing of stone, glass and jewelry.
- \* You can immediately operate the machine by plugging in the power supply. It is highly recommended if the working environment requires serenity.

AP-200 目錄頁數 P.13 / Page. 13



全新的設計, 具有強力的輸出以及精確的控制, 擁有多樣化的機種適合每種不同的研磨需求。各種的安全設計避免人員及設備損傷的風險。

貼心的功能設計, 搭配上精準的轉速控制, 讓工作更輕鬆。主機設計以及產地都是台灣製造, 兼顧了品質與價格優勢。拋光, 研磨, 雕刻都能輕鬆應付, 初學者也能輕鬆上手。

### 特長:

- \* 強勁的輸出功率 : 無刷機型最大250瓦的輸出功率, 有刷機型最大150瓦的輸出功率, 提供有效且快速之加工作業。
- \* 可接受廣域的輸入電壓 : 所有機型可接受的電源皆為AC90~250V, 50/60HZ, 不用再為了電源不符合而煩惱, 且安全有保障。
- \* 過載保護裝置 : 當手機處於過載時系統會自動斷電, 以保護機器以及手機不至於受損。
- \* 系統自動偵測 : 先進的高效率微處理器可以隨時偵測手機狀況, 精確地控制各種手機之輸出, 保護迴路及扭力補償及穩定轉速, 以發揮手機之最佳操作性能

U-Lap 60,50,35 目錄頁數 P.14 / Page.14



### 運用:

- \* 各種模具之研磨及拋光。
  - \* 需要精準控制轉速的加工。
  - \* 雕刻硬脆材料, 或其他需要高轉速的加工。
  - \* 石頭、玻璃、寶石等之精細研磨或拋光。
  - \* 只需要接上電源就可使用, 方便簡單!
- 工作環境需安靜的場合最為適合。

## 專業研磨與拋光工具 / Professional Grinding & Polishing Tools



鑽石磨棒  
Diamond Mounted Points

連結 / Link :



鑽石磨棒 (錐形)  
Diamond Taper Points

連結 / Link :



羊毛輪  
Felt Bobs

目錄頁數 P.20 / Page. 20



棕刷  
Brush

目錄頁數 P.19 / Page. 19



帶柄砂輪  
Mounted Points

目錄頁數 P.25 / Page. 25



彈性帶柄砂輪  
Elastic Mounted Points

目錄頁數 P.27 / Page. 27

※ 一品鑽石提供以上專業的拋光與研磨工具, 適用於所有的電動拋磨機使用, 歡迎選購  
 ※ 以上連結之QR CODE 可直接連線到一品鑽石的線上目錄, 若無法使用 QR CODE 請至 [www.besdia.com](http://www.besdia.com) 查閱詳細產品規格  
 ※ We supply professional polishing and grinding tools, your interest & business will be warmly welcomed.  
 ※ Please use QR Code to connect with BEST DIAMOND's catalogue online. Or please visit our website at [www.besdia.com](http://www.besdia.com)

**AR-800 (P) 雙功能輸出電源供應器**  
Dual-Function Micromotor Controller



- 全新設計旗艦型機種，採用先進的高效率微處理器設計，結合有刷及無刷馬達雙輸出。
- 有刷馬達輸出最大150瓦，無刷馬達輸出最大250瓦，使各種手機有更高的扭力，發揮其最佳的研磨效率。
- LED轉速顯示，使用無刷手機時，讓您可依據各種不同的工具及外徑，調整最合適的轉速，以達到最有效率且安全的研磨效果。
- 使用有刷手機時，LED數字顯示輸出電壓，一樣可以換算手機轉速，做最有效率且安全的研磨作業。
- 先進的高效率微處理器可以隨時偵測手機操作狀況，精準地控制各種手機之輸出，保護迴路及扭力補償及穩定轉速，以發揮手機之最佳操作性能。
- High Performance micro processor design. Compatible for both brush and brushless motor hand Handpiece.
- Maximum power for hand piece with brush is 150 watt and 250 watt for brushless motor hand piece, providing high torque and optimal polishing performance.
- LED RPM display. The display can be adjusted to suit different tools and sizes to reflect the appropriate RPM information. A safe and efficient polishing is guaranteed.
- During the use of hand piece with brush, the LED will display voltage, but it can also be converted to display RPM to promote safe and optimal performance operation.
- Advanced high performance micro processor can passively detect the working condition of the hand piece during usage, precisely adjusting various hand piece output, RPM and torque compensation accordingly and monitor to maintain the performance at maximum. The protection circuit is also monitored to provide best protection

**AR-800 (P) 雙功能輸出電源供應器 - 標準規格表**  
Rotary Micromotor Controller - Specification

電源 Main supply	AC-90V ~ 250V, 50/60 Hz
無刷輸出功率 / Power of DC brushless	250watt
無刷轉速 / Speed of DC brushless	1,000~50,000 rpm
有刷輸出功率 / Power of DC brush	150watt (VA)
有刷輸出電壓 / Voltage output of DC brush	5~32V
保險絲 / Fuse	3.15A
尺寸 / Dimension	170x260x140mm (2.56kg)

**AR-800(P)內含配件 / Include (Standard)**



**專業工具-選購 / Professional Tools ※Optional**

<p><b>鑽石磨棒</b> Diamond Mounted Points</p> <p>連結 / Link : </p>	<p><b>帶柄砂輪</b> Mounted Points</p> <p>目錄頁數 P.25 / Page. 25</p>
---	---

**基礎應用實例 / Applications**



**AR-800 (P) 可選配手機**  
AR-800 (P) Handpiece ※Optional

Model No. 型號	Specifications 規格
U-Lap60 旋轉手機/無刷型	<b>Rotary Handpiece (DC Brushless Type)</b> 轉速 / Speed : 50,000 rpm 扭力 / Torque : 7.8 Ncm 尺寸 / Dimension : Ø 29 x 161mm 重量 / Weight : 250g
U-Lap50 旋轉手機/有刷型	<b>Rotary Handpiece (DC Brush Type)</b> 轉速 / Speed : 40,000 rpm 扭力 / Torque : 4.5 Ncm 尺寸 / Dimension : Ø 29 x 153mm 重量 / Weight : 260g
U-Lap35 旋轉手機/有刷型	<b>Rotary Handpiece (DC Brush Type)</b> 轉速 / Speed : 35,000 rpm 扭力 / Torque : 2.9 Ncm 尺寸 / Dimension : Ø 29 x 152mm 重量 / Weight : 230g

\* 全部手機皆為選配商品，AR-800 (P) 內未包含，下單時請注意!  
\* All handpiece are Optional accessory, did not include in AR-800 (P)

**AP-300 無刷型電源控制器**  
Brushless Rotary Micromotor Controller



- 可使用於AC 90 ~240V, 50/60Hz的電源，不必切換任何開關，也沒有插錯電源而毀損機器的風險。
- LED數字轉速顯示，讓您可依據各種不同的工具及外徑，調整最合適轉速，以達到最有效率且安全的研磨效果。
- 內建過負載保護程式，確保手機不致因過載使用而損壞。
- 系統會自動偵測手機之使用狀況，隨時對各種操作條件給予不同的扭力補償以穩定操作轉速，充分發揮手機之操作性能。
- 建議搭配U-Lap 60無刷手機使用。
- 可選購一般開關型或可調速型腳踏開關。

- Can be plugged into AC 90 ~240V, 50/60Hz power outlet. No need to switch between different power outlets and eliminates the risk of plugging into wrong power rating outlet.
- LED RPM display. The display can be adjusted to suit different tools and sizes to reflect the appropriate RPM information. A safe and efficient polishing is guaranteed.
- Build in overload protection prevents the hand piece from damage during an overloading instance.
- The system will detect the current usage status of the hand piece and adjust the torque accordingly to stabilize the RPM. This feature ensures that the hand piece will always be at the optimal performance.
- U-Lap 60 Brushless hand piece is recommended to be paired with AP-300.
- U-Lap 60 Brushless hand piece is recommended to be paired with Conventional On-Off pedal switch and Adjustable pedal switch are optional.

**AP-300 無刷型電源控制器**  
Brushless Rotary Micromotor Controller

電源 Main supply	AC 90 ~ 250V, 50/60Hz
無刷輸出功率 / Power of DC brushless	100watt
無刷轉速 / Speed of DC brushless	1,000~50,000 rpm
保險絲 / Fuse	2A
尺寸 / Dimension	192x146x98mm (800g)

**AP-300內含配件 / Include (Standard)**



**專業工具-選購 / Professional Tools ※Optional**

<p><b>鑽石磨棒</b> Diamond Mounted Points</p> <p>連結 / Link : </p>	<p><b>羊毛輪</b> Felt Bobs</p> <p>目錄頁數 P.21 / Page. 21</p>
---	---

**基礎應用實例 / Applications**



**AP-300 可選配手機**  
AP-300 Handpiece ※Optional

Model No. 型號	Specifications 規格
U-Lap60 旋轉手機/無刷型	<b>Rotary Handpiece (DC Brushless Type)</b> 轉速 / Speed : 50,000 rpm 扭力 / Torque : 7.8 Ncm 尺寸 / Dimension : Ø 29 x 161mm 重量 / Weight : 250g

\* U-Lap 60 手機為選配商品，AP-300 內未包含，下單時請注意!  
\* U-Lap handpiece are Optional accessory, did not include in AR-300



**AP-200 有刷型多功能電源控制器**  
Multiple Functional Brush Rotary Power Controller



- AP-200為先進設計的電源控制器，此電源供應器提供了三功能輸出選擇：正常功能、緩啟動功能及扭力自動補償功能。
- 過負載保護裝置：當電動手機處於過載時系統會自動斷電，以保護機器及手機不至於受損。
- 可以選購一般開關型或可調速型腳踏開關。
- AP-200 is a more advanced Power Controller for hand piece with brush. That provide there different output functions: Normal, slow-start, and self torque compensation.
- Overload Protection: The system will be shut down when an overload occurs to protect the controller and hand piece from damage.
- Conventional On-Off pedal switch and Adjustable pedal switch are optional.

**AP-200 可選配手機**  
AP-200 Handpiece \*Optional

Model No. 型號	Specifications 規格
U-Lap50 旋轉手機/有刷型	<b>Rotary Handpiece (DC Brush Type)</b> 轉速 / Speed : 40,000 rpm 扭力 / Torque : 4.5 Ncm 尺寸 / Dimension : Ø 29 x 153mm 重量 / Weight : 260g
U-Lap35 旋轉手機/有刷型	<b>Rotary Handpiece (DC Brush Type)</b> 轉速 / Speed : 35,000 rpm 扭力 / Torque : 2.9 Ncm 尺寸 / Dimension : Ø 29 x 152mm 重量 / Weight : 230g

\*全部手機皆為選配商品, AP-200 內未包含, 下單時請注意!  
\*All handpiece are Optional accessory, did not include in AP-200

- **正常功能輸出 (N) :** 當一般操作時使用, 此時系統依一般功能輸出。  
Normal Output (N) : For use during typical operation
- **緩啟動功能 (S) :** 當您切換至此功能時, 即使將輸出調到最高轉速, 系統仍然控制手機於最低轉速, 但接觸工件開始研磨時, 系統會自動地將轉速提升到最高轉速。這個功能主要運用於避免高速運轉時不小心去磨到不想磨到或不能磨到的部位, 您可以很精確地控制想加工的地方。此外, 對於工件表面凹凸不平處這個功能也能減少研磨時之跳動。  
Slow Start (S) : When switched to this mode, the system will control the RPM to the lowest speed when the hand piece is at idle and when the hand piece detect any object, the RPM will rise to the set speed. The main purpose of this function is to reduce the risk of having accident from happening during high RPM application. We can point at the work area more easily and precisely. This will reduce the chance of accidentally touching wrong spot. When working on subjects with uneven surfaces under this mode, can keep the hand piece at stable position more easily
- **扭力自動補償功能 (IR) :** 當您使用一些直徑較大(如Ø20mm砂布輪)或不能高速使用的工具(如鬃刷輪)時, 由於研磨壓力使轉速下降或較低轉速時扭力較低, 當切換至此功能時系統會自動補償扭力穩定轉速。一般研磨工具建議使用正常功能輸出。  
Automatic torque Compensation (IR) : When using any large diameter tools or low RPM tools, the RPM will be slowed down due to the friction. When IR mode is turned on, The system will compensate for the loss of speed to stabilize the RPM. When using normal tools, normal function is recommended.

**AP-200 有刷型多功能電源控制器**  
Multiple Functional Brush Rotary Power Controller

電源 Main supply	AC-90V ~ 250V, 50/60 Hz
有刷輸出功率 / Power of DC brush	70watt
有刷輸出電壓 / Voltage output of DC brus	5~32V
最大過載保護 / Max Overload Current Protection	3A
保險絲 / Fuse	2A
尺寸 / Dimension	192x156x98mm (800g)

**AP-200 內含配件 / Include (Standard)**



**AP-200 功能簡介 / Features of functions**



**專業工具-選購 / Professional Tools \*Optional**

**鑽石磨棒 (錐形) / Diamond Taper Points**



**彈性帶柄砂輪 / Elastic Mounted Points**



**基礎應用實例 / Applications**



**U-Lap 60 無刷旋轉手機 / 高扭力高轉速型**  
Rotary Handpiece (Brushless Type) / High Torque & Speed Type

可對應之電源供應器  
Optional Power Controller

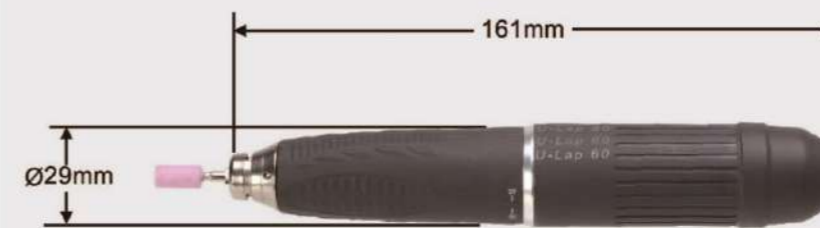

型號 / Order No. : U-Lap 60  
轉速 / Speed : 50,000 rpm  
扭力 / Torque : 7.8 Ncm  
重量 / Weight: 250g

內容物 :   
Include :

可更換式夾頭: 標準夾頭 Ø3mm, 亦可選購 Ø2.34mm 或 Ø3.175mm 夾頭  
Replaceable collet chuck : Ø3.0mm is standard, the Ø2.34mm and Ø3.175mm collet are optional.



**U-Lap 50 有刷旋轉手機 / 高轉速型**  
Rotary Handpiece (Brush Type) / High Speed Type

可對應之電源供應器  
Optional Power Controller

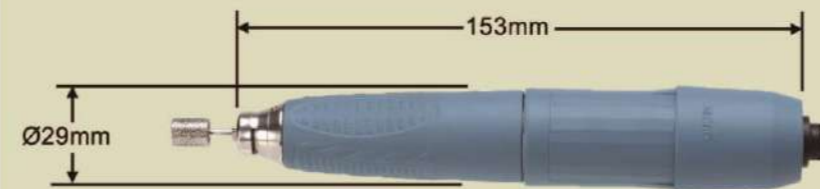

型號 / Order No. : U-Lap 50  
轉速 / Speed : 40,000 rpm  
扭力 / Torque : 4.5 Ncm  
重量 / Weight: 260g

內容物 :   
Include :

可更換式夾頭: 標準夾頭 Ø3mm, 亦可選購 Ø2.34mm 或 Ø3.175mm 夾頭  
Replaceable collet chuck : Ø3.0mm is standard, the Ø2.34mm and Ø3.175mm collet are optional.



**U-Lap 35 有刷旋轉手機 / 經濟型**  
Rotary Handpiece (Brush Type) / Economic Type

可對應之電源供應器  
Optional Power Controller



型號 / Order No. : U-Lap 35  
轉速 / Speed : 35,000 rpm  
扭力 / Torque : 2.9 Ncm  
重量 / Weight: 230g

內容物 :   
Include :

可更換式夾頭: 標準夾頭 Ø3mm, 亦可選購 Ø2.34mm 或 Ø3.175mm 夾頭  
Replaceable collet chuck : Ø3.0mm is standard, the Ø2.34mm and Ø3.175mm collet are optional.





進氣壓力 / Air Pressure	重量 / Weight	尺寸 / Dimension
90psi (6.2kg/cm <sup>2</sup> )	110g	Ø20x160L (mm)

- UG-500標準型 Standard type**
- 高扭力、低噪音、精密型刻磨機。
  - 適用於精密研磨及修整作業。
  - 可更換式夾頭：標準夾頭為 Ø3.0mm，亦可選購 Ø2.34或 Ø3.175mm 為夾頭。
  - High-torque, quiet-running and well balance.
  - Ideal for precision grinding and finishing works.
  - Replaceable collet chuck : Ø3.0mm is standard, the Ø2.34 and Ø3.175mm collet are optional.



進氣壓力 / Air Pressure	重量 / Weight	尺寸 / Dimension
90psi (6.2kg/cm <sup>2</sup> )	130g	Ø17x159L (mm)

- UG-400經濟型 Economic type**
- 經濟型，適用於精密研磨及修整作業。
  - 夾頭不可更換：標準品為 Ø3.0mm 夾頭，若須 Ø2.34 或 Ø3.175mm 夾頭請指明選購。
  - 低耗風量，高扭力，品質佳。
  - Reliable quality and competitive price.
  - Fixed type collet chuck : Ø3.0mm is standard, the tool with Ø2.34 and Ø3.175mm collet are optional.



進氣壓力 / Air Pressure	重量 / Weight	尺寸 / Dimension
90psi (6.2kg/cm <sup>2</sup> )	180g	Ø17.5x142L (mm)

- GP-260 精密型 Precision type**
- 精密型，適用於精密研磨及修整作業。
  - 夾頭不可更換，標準品為 Ø3.0mm 夾頭。
  - Ø2.34 或 Ø3.175mm 請指名選購。
  - High-torque, quiet-running and well balance.
  - Ideal for precision grinding and finishing works.
  - Fixed type collet chuck : Ø3.0mm is standard, the tools with Ø2.34mm or Ø3.175mm collet are optional.



進氣壓力 / Air Pressure	重量 / Weight	尺寸 / Dimension
90psi (6.2kg/cm <sup>2</sup> )	160g	Ø20.3x143L (mm)

- GP-380 高速型 High speed type**
- 高轉速、精密型刻磨機。
  - 適用於精密研磨及雕刻作業。
  - 可更換式夾頭：標準夾頭為 Ø3.0mm，亦可選購 Ø2.34 或 Ø3.175mm 為夾頭。
  - High speed, quiet-running and well balance.
  - Ideal for precision grinding and finishing works.
  - Replaceable collet chuck : Ø3.0mm is standard, the Ø2.34 and Ø3.175mm collet are option

專業研磨與拋光工具  
Grinding & Polishing Tools

鑽石磨棒  
Diamond Mounted Points



帶柄砂輪  
Mounted Points



彈性帶柄砂輪  
Elastic Mounted Points



進氣壓力 / Air Pressure	重量 / Weight	尺寸 / Dimension
90psi (6.2kg/cm <sup>2</sup> )	170g	Ø22x180L (mm)

- UG-300 雙夾頭型 Dual-Collet type**
- 重負荷、高扭力，泛用型適於清除毛邊倒角、鎢鋼刀銑磨及焊接面磨除等。
  - 雙夾頭兩用型：標準夾頭為 Ø3.0/Ø6.0mm 夾頭，亦可選購 Ø3.175 或 Ø6.35mm 為夾頭。
  - High torque, heavy-duty, general-purpose applicable on deburring, chamfering, milling and finishing the welded surfaces...etc.
  - Dual collet chuck : Ø3.0 / Ø6.0mm is standard, the collet of Ø3.175 / Ø6.35mm is optional.



進氣壓力 / Air Pressure	重量 / Weight	尺寸 / Dimension
90psi (6.2kg/cm <sup>2</sup> )	200g	Ø16.5x136L (mm)

- GP-522 平面研磨機 Angle Surface grinder**
- 120度彎頭研磨機
  - 夾頭：M7 螺桿，可鎖接碗型砂輪或砂布片。
  - 適用於平面研磨，倒角及焊接面之修整。
  - 120 degree angle surface grinder.
  - Collet chuck: M7 screw shaft for mounting abrasive cup sheets and abrasive paper disc.
  - Ideal for surface grinding, chamfering, deburring and finishing the welded surfaces...etc.



進氣壓力 / Air Pressure	重量 / Weight	尺寸 / Dimension
90psi (6.2kg/cm <sup>2</sup> )	180g	Ø17x153Lx50H (mm)

- AG-45 平面研磨機 Angle Surface grinder**
- 45度彎頭平面研磨機，適用於平面研磨，倒角及焊接面之修整。
  - 夾頭：M7 螺桿，可鎖接碗形輪或砂布片。
  - 45 degree angle surface grinder.
  - Collet chuck: M7 screw shaft for mounting abrasive cup wheels and abrasive paper disc.
  - Ideal for surface grinding, chamfering, deburring and finishing the welded surfaces...etc.



進氣壓力 / Air Pressure	重量 / Weight	尺寸 / Dimension
90psi (6.2kg/cm <sup>2</sup> )	170g	Ø17x140x39H (mm)

- AG-90 平面研磨機 Angle Surface grinder**
- 90度彎頭平面研磨機，適用於平面研磨，倒角及焊接面之修整。
  - 夾頭：M7 螺桿，可鎖接碗形輪或砂布片。
  - 90degree angle surface grinder.
  - Collet chuck: M7 screw shaft for mounting abrasive cup wheels and abrasive paper disc.
  - Ideal for surface grinding, chamfering, deburring and finishing the welded surfaces...etc.

專業研磨與拋光工具  
Grinding & Polishing Tools

Ø6mm 鑽石磨棒  
Ø6mm Diamond Points



羊毛輪  
Felt Bobs



碗型小砂輪 / 砂布片  
Cup Wheel / Paper Disc



連接三點組合 / 3-in-1 Units

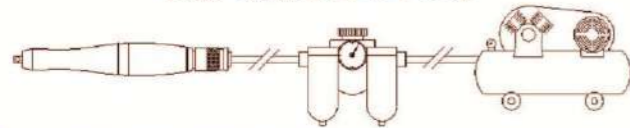

潤滑，濾水，控制壓力 / Filter, Regulator, Lubricator



使用需潤滑  
(Need lubricator oil)



請配戴耳罩  
(Use ear plug)



請配戴護目鏡  
(Use eye protector)

連接三點組合 / 3-in-1 Units

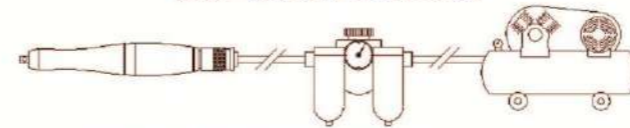

潤滑，濾水，控制壓力 / Filter, Regulator, Lubricator



使用需潤滑  
(Need lubricator oil)



請配戴耳罩  
(Use ear plug)



請配戴護目鏡  
(Use eye protector)



行程 / Stock	進氣壓力 / Air Pressure	重量 / Weight	尺寸 / Dimension
0.15mm	90psi (6.2kg/cm <sup>2</sup> )	190g	Ø28x200L (mm)

**微行程渦輪式氣動超音波**  
UTR-20 Micro Stroke Turbo Air Lappers

- 超高速、微動行程(0.15mm)機種，最適於微細部位及邊角部位之研磨。
- 超低振動，加工角落時沒有撞擊感。
- High speed, micro stroke(0.15mm) and low vibration.
- It suits for details and corner area's lapping.



行程 / Stock	進氣壓力 / Air Pressure	重量 / Weight	尺寸 / Dimension
0.3mm	90psi (6.2kg/cm <sup>2</sup> )	220g	Ø28x200L (mm)

**渦輪式氣動超音波**  
UTR-30 Turbo Air Lappers

- 使用氣動渦輪馬達，維修容易。
- 低噪音、低振動、壽命長。
- UTR-30 適合模具細微部分之加工。
- Driven by turbine air motor.
- Low noise, low vibration and durable tool life.
- UTR-30 suits for detail area's lapping.



行程 / Stock	進氣壓力 / Air Pressure	重量 / Weight	尺寸 / Dimension
0.7mm	90psi (6.2kg/cm <sup>2</sup> )	220g	Ø28x200L (mm)

**渦輪式氣動超音波**  
UTR-70 Turbo Air Lappers

- 使用氣動渦輪馬達，維修容易。
- 低噪音、低振動、壽命長。
- UTR-70適用於高效率及較大面積之研磨。
- Driven by turbine air motor.
- Low noise, low vibration and durable tool life.
- UTR-70 suits for general purpose polishing and finishing process of mold and die.



行程 / Stock	進氣壓力 / Air Pressure	重量 / Weight	尺寸 / Dimension
0.5mm	90psi (6.2kg/cm <sup>2</sup> )	220g	Ø23x185L (mm)

**超高速往復式氣動銼磨機**  
UR-50 Ultra Air Lappers

- 超高速、高扭力機種。
- UR-50 適用於高效率之研磨及清除毛邊或倒角。
- Extra High speed, high torque.
- UR-50 features in efficiency polishing and deburring or chamfering work.

專業研磨與拋光工具  
Grinding & Polishing Tools

鑽石機械平斜銼  
Diamond Tapered Machine Files



鑽石機械銼刀  
Diamond Machine Files



陶瓷纖維油石  
Ceramic Fiber Stones



UR-120 行程 / Stock	UR-300 行程 / Stock	進氣壓力 / Air Pressure	重量 / Weight	尺寸 / Dimension
1.2 mm	3.0 mm	90psi (6.2kg/cm <sup>2</sup> )	370g	Ø30x208L (mm)

**往復式氣動銼磨機**  
UR-120, UR-300 Recipro Air Lappers

- 高扭力、低噪音、低振動。
- 較長行程適合大面積之研磨，並適合各種鑄件或零件之清除毛邊及倒角。
- High-torque, quiet-running and low vibration.
- Long reciprocating stroke suits for lapping big surfaces, and excellent for deburring or chamfering works of die casting parts.



US-70 行程 / Stock	US-100 行程 / Stock	進氣壓力 / Air Pressure	重量 / Weight	尺寸 / Dimension
0.7 mm	1.0 mm	90psi (6.2kg/cm <sup>2</sup> )	305g	Ø28x205L (mm)

**左右橫擺式氣動銼磨機**  
US-70, US-100 Swing Air Lappers

- 特殊設計使主要磨耗零件十分容易更換。
- 氣動左右橫擺行程。
- 適合模具淺溝、深肋及公母模接合面等之研磨，防止研磨時工具滑落而傷及模具之銳角。
- Side to side stocke
- Special design enable the easiest method of changing the consuming or worn out parts.
- Ideal for filing lapping and polishing shallow surfaces, deep ribs and parting lines.



行程 / Stock	進氣壓力 / Air Pressure	重量 / Weight	尺寸 / Dimension
2.0mm	90psi (6.2kg/cm <sup>2</sup> )	520g	Ø34x205L (mm)

**左右橫擺式氣動銼磨機**  
US-200 Swing Air Lappers

- 氣動左右橫擺行程。
- 較大行程，適於較大面積之研磨，並適合各種鑄件或零件之清除毛邊及倒角。
- Side to side stocke.
- Bigger swing stroke suit for lapping bigger surface and excellent for deburring or chamfering works for die casting parts.

專業研磨與拋光工具  
Grinding & Polishing Tools

鑽石銼刀片  
Diamond Tip Files



木條  
Wood Stick



EDM / DF 油石  
Oil Polishing Stones



連接三點組合 / 3-in-1 Units

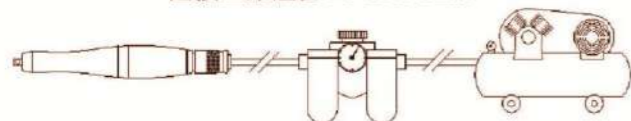

潤滑，濾水，控制壓力 / Filter, Regulator, Lubricator



使用需潤滑  
(Need lubricator oil)



請配戴耳罩  
(Use ear plug)



請配戴護目鏡  
(Use eye protector)

連接三點組合 / 3-in-1 Units

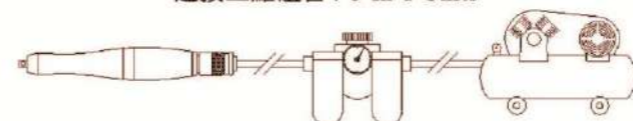

潤滑，濾水，控制壓力 / Filter, Regulator, Lubricator



使用需潤滑  
(Need lubricator oil)



請配戴耳罩  
(Use ear plug)



請配戴護目鏡  
(Use eye protector)

木條  
Lapping Wood

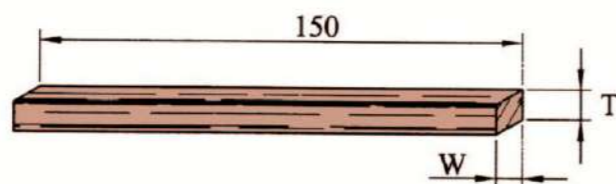

Order.no.	AFW-05H	AFW-06H	AFW-07H	AFW-08H
T x W	6.4 x 6.4	3.2 x 6.4	6.4 x 9.5	6.4 x 12.7

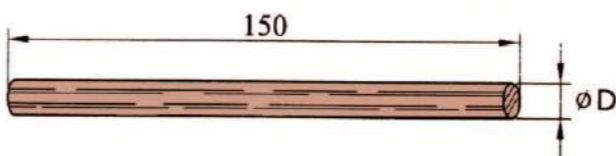

Order.no.	AFW-01H	AFW-02H	AFW-03H	AFW-04H
ø D	ø 3.2	ø 4.7	ø 6.4	ø 9.5

單位 / Unit : mm

木棒  
Wood Bobs

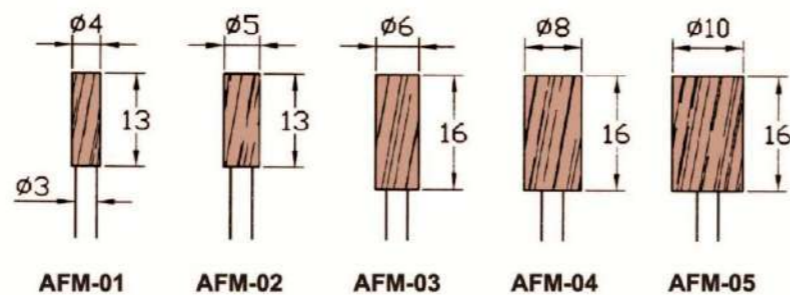

單位 / Unit : mm

棕刷  
Brush



Order no.	AFB-01	AFB-02	AFB-03	AFB-04	AFB-05	AFB-06
ø D	ø 4.8	ø 6.4	ø 19	25.4	ø 9/16"	ø 1"

單位 / Unit : mm

羊毛輪  
Felt Bobs - ø3.0mm Shank

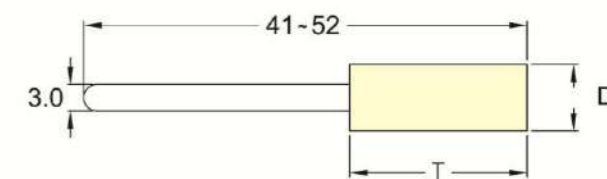

單位 / Unit : mm

Order no.	AB-0410A	AB-0509A	AB-0610A	AB-0810A	AB-1014A	AB-1220A	AB-1520A
ø D	4	5	6	8	10	12	15
T	10	9	10	10	14	20	20

Order no.	AB-2020A	AB-0408C	AB-0509C	AB-0610C	AB-0810C	AB-1013C	AB-1214C
ø D	20	4	5	6	8	10	12
T	20	8	9	10	10	13	14

Order no.	AB-1220C	AB-0410J	AB-0512J	AB-0616J	AB-0817J	AB-1014J	AB-1020J
ø D	12	4	5	6	8	10	10
T	20	10	12	16	17	14	20

Order no.	AB-1220J	AB-1225J	AB-08B	AB-10B	AB-12B	AB-18B	AB-1014R
ø D	12	12	8	10	12	18	10
T	20	25	-	-	-	-	14

Order no.	AB-1225R	AB-1218T	AB-1218H	AB-0610K	AB-0814K	AB-1014K	AB-1220K
ø D	12	12	12	6	8	10	12
T	25	18	18	10	14	14	20

羊毛輪

Felt Bobs -  $\phi 6.0$ mm Shank

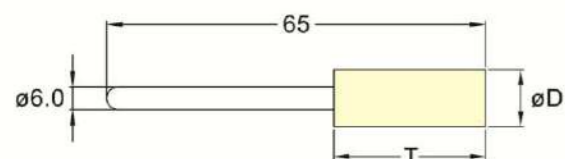

單位 / Unit : mm

	Order No.	$\phi D$	T
	AC-1225A	12	25
	AC-1525A	15	25
	AC-2025A	20	25
	AC-2530A	25	30
	AC-1520C	15	20
	AC-2025C	20	25
	AC-2530C	25	30
	AC-3208E	32	8
	AC-4010E	40	9.6
	AC-1525K	15	25
	AC-2025K	20	25
	AC-2530K	25	30

其他羊毛製品

Other Felt Products

單位 / Unit : mm

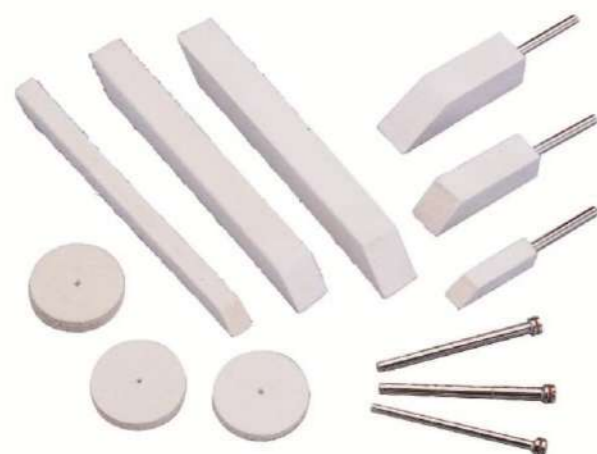

羊毛條 / Felt Stick

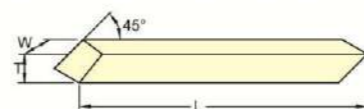

Order.no.	AB-S06	AB-S10
W x T x L	6 x 6 x 100 x 45°	10 x 10 x 100 x 45°

帶柄羊毛條 / Mounted Felt Stick

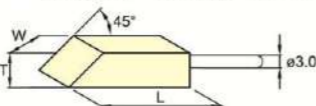

Order.no.	AB-R06	AB-R10	AB-R12
W x T x L	6 x 6 x 25	10 x 10 x 35	12 x 12 x 45

羊毛片 / Felt Disc

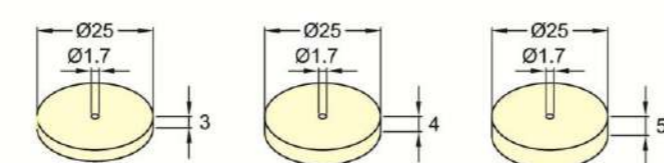

AB-2503E AB-2504E AB-2505E

軸柄 / Mandrel For Felt Disc

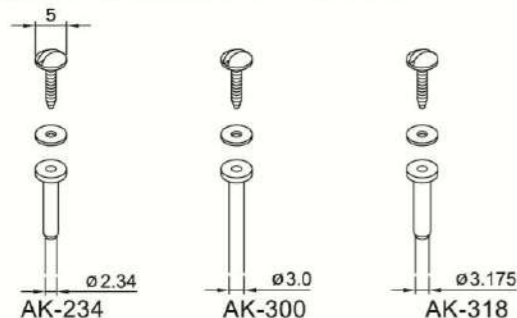

AK-234 AK-300 AK-318



全新的貝斯迪亞® 纖維油石，採用精選陶瓷纖維以獨特的結合材料及製造方法，比以前我們銷售的產品，有下列優點：

- 有更好的抗折強度，使纖維油石更不易折斷。
- 在相同的工作條件下，增加 10 ~ 20% 以上的研磨效率。
- 在絕大多數的工作條件下，增加 10 ~ 30% 以上的研磨比 (工具壽命更長)

All **New BESDIA® Ceramic Fiber Stone** use the special ceramic fibers combined with the unique bonding material and manufacturing process. Compare to the previous one we sold:

- Our improvements in production processes give better tensile strength to the stones, hence fewer breakages.
- A polishing efficiency increase of 10% to 20% has been achieved.
- Durability under the same working conditions has been increased by 10% to 30%.

規格 / Specifications :

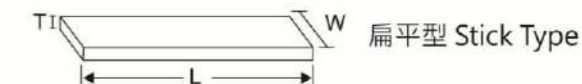

粒度與顏色 / Grit Size & Color Code :

粒度 / Grit size	#180	#250	#320	#400	#700	#1000	#1200
顏色 Color code	咖啡色 Coffee	橙色 Orange	灰色 Grey	藍色 Blue	黃色 Yellow	白色 White	橘紅色 Red Orange
代號 / Code	C	O	G	B	Y	W	R

粒度與編號 / Grit Size & Order No :

單位 / Unit : mm

T x W x L ( $\phi D$ x L)	粒度與編號 Grit Size & Order No.						
	#180	#250	#320	#400	#700	#1000	#1200
1 x 4 x 100	BSC-1004	BSO-1004	BSG-1004	BSB-1004	BSY-1004	BSW-1004	BSR-1004
1 x 6 x 100	BSC-1006	BSO-1006	BSG-1006	BSB-1006	BSY-1006	BSW-1006	BSR-1006
1 x 10 x 100	BSC-1010	BSO-1010	BSG-1010	BSB-1010	BSY-1010	BSW-1010	BSR-1010
$\phi 3.0$ x 100	BGC-30	BGO-30	BGG-30	BGB-30	BGY-30	BGW-30	BGR-30

說明：#320 灰色可取代舊有的 #280 黑色及 #360 海軍藍。  
Note: #320 Grey instead of #280 Black and #360 Navy Blue of old stones.

## 迷你纖維油石 / Mini Ceramic Fiber Stones



迷你纖維油石是將纖維油石切成微細尺寸，從0.5 x 0.5mm到1 x 2mm。專門使用於各種模具之細微部位或是其他類似之加工。由於陶瓷纖維具有高抗折強度，可解決一般油石或紅寶石易斷的困擾。

**用途：**  
迷你纖維油石可適用於各種模具之研磨及各種零件之精細拋光。尤其是雕刻部位之加工，微小

**Mini Ceramic Fiber Stones** are cut by ceramic fiber stone, their size from 0.5 x 0.5 mm to 1 x 2mm. Ideal for various mold and dies lapping.

**Traditional oil stone** and ruby stones in such a small sizes are very easy to break, while mini ceramic stone provide high strength and high elasticity. Due to its hard to break, they resolve the problem of using these stones.

**Applications**  
It is good for all type of molds and dies fine and super fine finishing. Especially for engraving parts, slight ribs, R ribs, corners, complicated area and details.

Besides, all other tool parts that needs details lapping, Our mini ceramic fiber stone will be the wonderful tools.

### 規格 / Specifica:

尺寸 (mm) Dimensions (mm)	粒度與編號 Grit Size & Order No.				使用夾頭 Holder
	#250	#400	#700	#1200	
0.5 x 0.5 x 50L	MOS-055	MBS-055	MYS-055	MRS-055	XH-007
0.7 x 0.7 x 50L	MOS-075	MBS-075	MYS-075	MRS-075	XH-009
0.9 x 0.9 x 50L	MOS-095	MBS-095	MYS-095	MRS-095	XH-013
1.0 x 2.0 x 100L	MOS-121	MBS-121	MYS-121	MRS-121	XH-200
ø 0.9 x 50L	MOG-105	MBG-105	MYG-105	MRG-105	XH-009
ø 2.0 x 100L	MOG-201	MBG-201	MYG-201	MRG-201	XH-200

### Application Example



## 油石夾柄 / Tool Holders



單位 / Unit : mm

編號 Order No.	可挾持尺寸 Holding Capacity	運用 Applications
XH-007	Square 0.5 x 0.5 or Round ø 0.7	迷你纖維油石 For Mini Fiber Stone
XH-009	Square 0.7 x 0.7 or Round ø 0.9	迷你纖維油石 For Mini Fiber Stone
XH-200	Flat 2 x 1 or Round ø 2.0	迷你纖維油石 For Mini Fiber Stone
XH-013	Square 0.9 x 0.9 or Round ø 1.3	迷你纖維油石 For Mini Fiber Stone
XH-22	Round ø 3.0	纖維油石 For Fiber Stone
XH-041	平形 / Flat 4 x 1	纖維油石 For Fiber Stone
XH-061	平形 / Flat 6 x 1	纖維油石 For Fiber Stone
XH-101	平形 / Flat 10 x 1	纖維油石 For Fiber Stone
XH-062	平形 / Flat 6 x 2 ~ 6 x 3	一般油石 For Oil Stone
XH-133	平形 / Flat 13 x 3	一般油石 For Oil Stone
XH-136	平形 / Flat 13 x 6.3	一般油石 For Oil Stone



規格 / Specifications:

單位 / Unit : mm

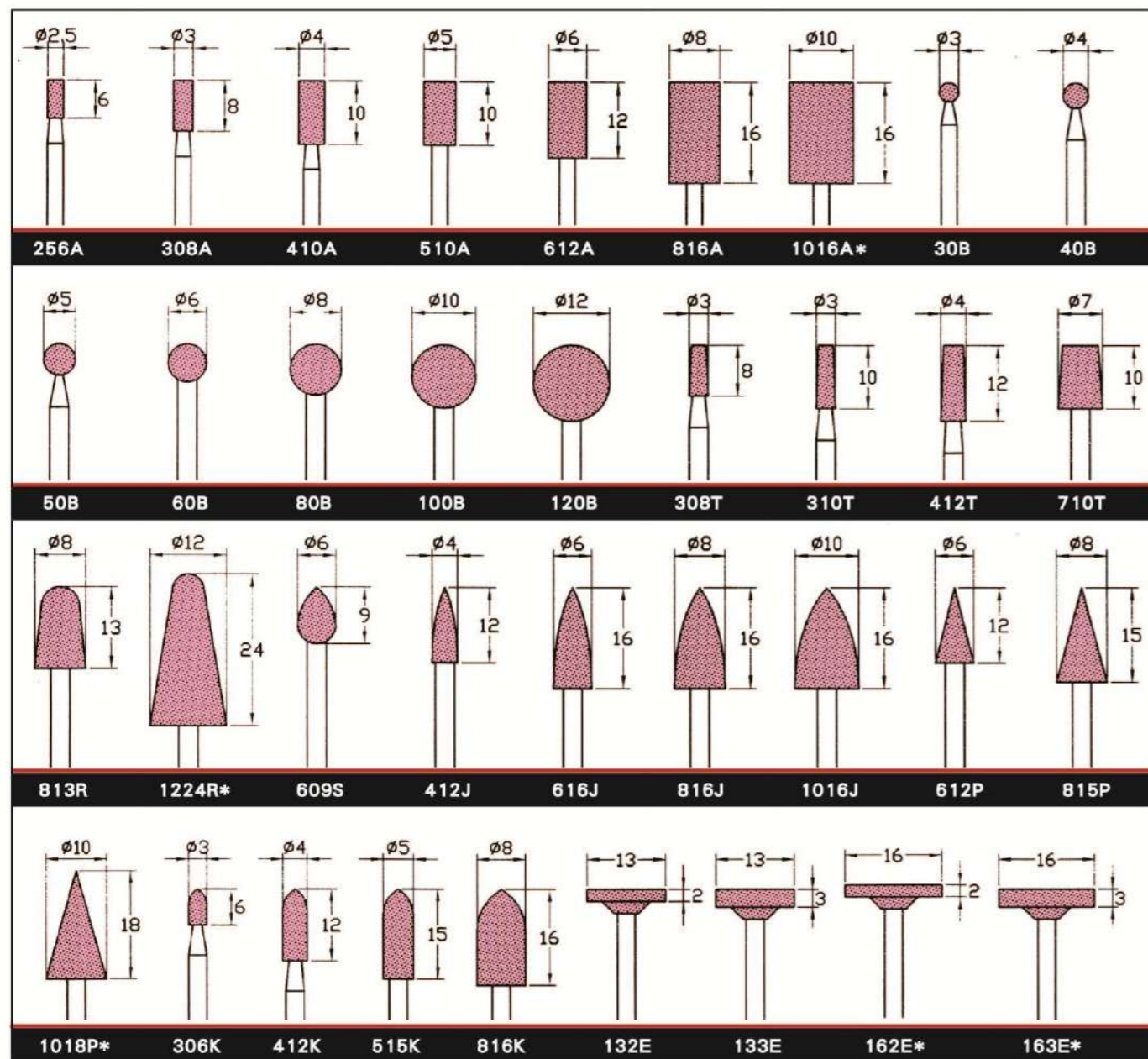

說明 / Note :

- 標準柄徑為Ø3.0mm,其他柄徑為 Ø2.34mm或 Ø3.175,請指明訂購。  
Ø3.0mm shank is standard, others (Ø2.34 or Ø3.175mm) depend on request.
- 有\*之尺寸,無法提供Ø2.34mm柄。  
The tools with "\*" marked, just available for Ø3.0 & Ø3.175 shank.



- EDM 系列油石 :  
主要用來去除各種模具EDM加工後之硬化表層。
- DF 系列油石 :  
主要使用於一般模具機械加工之痕跡去除及拋光作業。
- EDM series stones are specially for removing the hard scale generated by the EDM process on all type of mold and die steels.
- DF series stones are suitable for removing the machined surface scratch and general lapping & polishing all mold and die steels.

形狀·尺寸·粒度 / Shape · Dimension · Grit Size

形狀 / Shape	尺寸 / Dimension	粒度 / Grit Size
長方形 / Rectangle 	6x3x150mm(1/4"x1/8"x6")	#120, #180, #220, #320, #400, #600, #800, #1000, #1200
	6x6x150mm(1/4"x1/4"x6")	
	13x1.5x150mm(1/2"x1/16"x6")	
	13x3x150mm(1/2"x1/8"x6")	
	13x6x150mm(1/2"x1/4"x6")	
	13x13x150mm(1/2"x1/2"x6")	
	25x3x150mm(1"x1/8"x6")	
	25x6x150mm(1"x1/4"x6")	
	25x13x150mm(1"x1/2"x6")	
	10x10x150mm(3/8"x3/8"x6")	
圓形 / Round Type 	6mm圓x150mm(1/4"圓x6") 6mm Roundx150mm	#120, #180, #220, #320, #400, #600, #800, #1000, #1200
半圓形 / Half Round Type 	6mm半圓x150mm(1/4"半圓x6") 6mm Half Roundx150mm	#120, #180, #220, #320, #400, #600, #800, #1000, #1200
三角形 / Triangle Type 	6mm三角x150mm(1/4"三角x6") 6mm Trianglex150mm	#120, #180, #220, #320, #400, #600, #800, #1000, #1200

以上規格以及粒度為標準品,若您有特別需要的規格或粒度,請與我們聯絡。  
Above specifications are standards, Customization Available.

橡膠皿.砂布片.碗型砂輪 / Rubber Pad. Paper Disc. Cup Wheels  
 彈性帶柄砂輪 / Elastic Mounted Points

橡膠皿.砂布片.碗型砂輪  
 Rubber Pad. Paper Disc. Cup Wheels

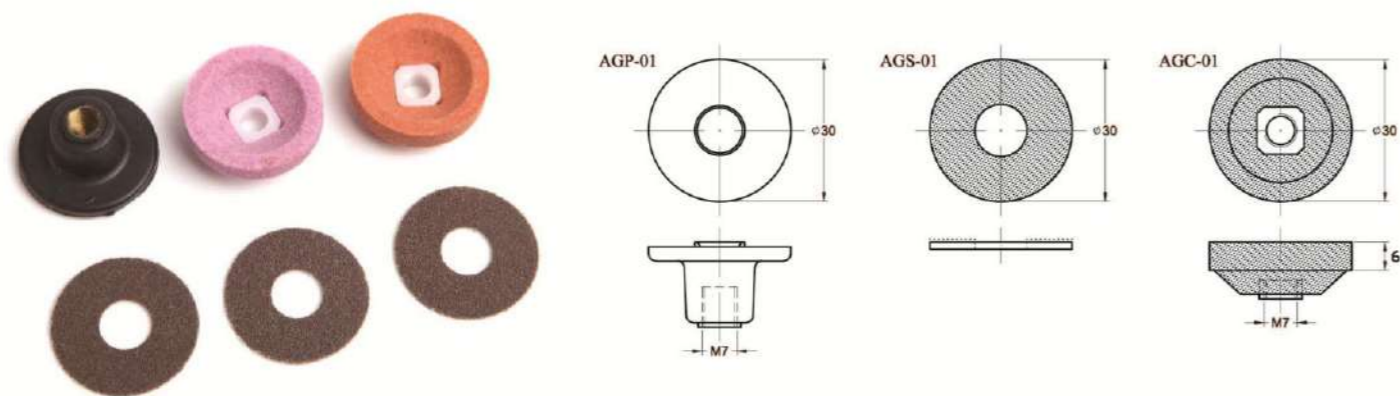

型號 / Order no.	規格 / Description	粒度 / Grit size available	包裝單位 / Unit
AGP-01	橡膠皿 / Rubber Pad	-	1 piece
AGS-01	砂布片 / Paper Disc	#60, #100, #150, #240 #320, #400, #600	150 pcs. / box(盒裝)
AGC-01	碗型砂輪 / Cup Wheels	#60, #100, #150	48 pcs. / box(盒裝)

備註 / Note : 適用機型GP-522, AG-45, AG-90 Standard accessory tools of GP-522, AG-45, AG-90

彈性帶柄砂輪  
 Elastic Mounted Points

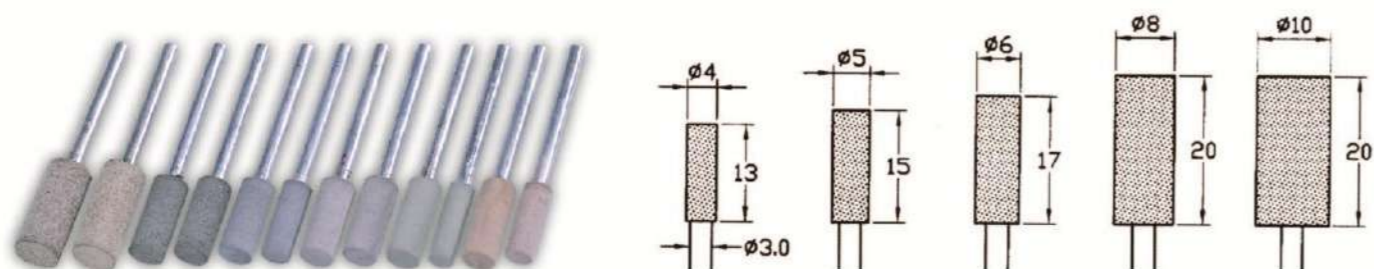

產品名稱 / Products	粒度 / Grit Size	編號 / Order No.				
牛皮帶柄砂輪 Resinoid Mounted Point	#120	N413	N515	N617	N820	N1020
海綿帶柄砂輪 Rubberize Mounted Point	#120	R413	R515	R617	R820	R1020
陶瓷帶柄砂輪 Ceramic Mounted Point	#120, #220, #320	C413	C515	C617	C820	C1020

包裝單位 / Unit : 100pcs / Box(100支/盒)

Evolved Emerged  
 Transcended  
 破繭而出 超越自我 再創高峰

BEST

Besdia®



一品鑽石提供各式  
 專業鑽石與CBN工具  
 並提供客戶  
 訂製服務

Providing professional and  
 general-purpose Diamond &  
 CBN Tools to integrate  
 your full demand is  
 our advantage.



訂購專線 TEL : +886 2 8976-9341 傳真 FAX : +886 2 8976-9343 網址 website : www.besdia.com